

Rendezvous Collection
10mm Radius Undermount
Extra Large Single Bowl
 Sliding Platform System
Model : REN-16-4518S

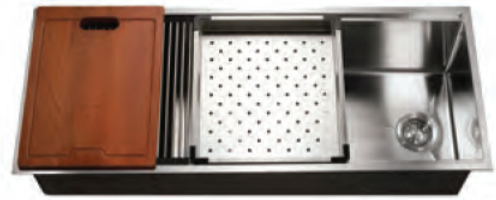

****Installation note: Recommended minimum of 3/4" between front of faucet base and rear edge of sink cut-out for cutting board clearance****

FEATURES

- Premium grade T-304 stainless steel
- Handmade sink with scored bottom
- 9" depth • 16 gauge
- TotalGuard+ Insulation over Sound Deadening Pads
- StoneShield Undercoating
- Brushed satin, offset 3-1/2" drain opening
- Fits 48" sink base
- Supplied with cutout template, fasteners and instructions
- All accessories designed to fit platform ledge except cutting board
- Includes: Wood Cutting Board, Drying Trays, Multi-Purpose Roll-Up Mat, Bottom grids, Stainless Steel Basket Strainer
- Lifetime Limited Warranty



OPTIONAL ACCESSORIES

Bottom Grid: SWG-2315R , SWG-2315L Roll-Up Mat: ROL-1416
 Drying Tray: DRY-716, DRY-1617 Cutting Board : CUT-1418
 Strainer: BAS-2000-SS

REN-16-4518S

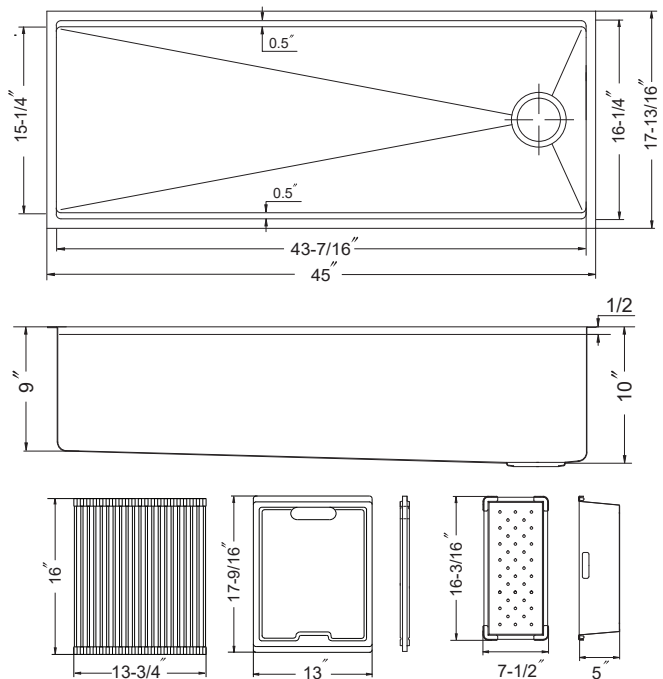

OVERALL DIMENSIONS	EACH BOWL	CUTOUT SIZE	PACKAGING*	WEIGHT*
45" x 17-13/16"	43-7/16" x 15-1/4"	See Template	1/12 pcs.	45/580 lbs.

*Standard packaging: Single boxed /Pallet of single boxed.
 All dimensions are in inches. Specifications subject to change without notice.

Project/Job name _____

Architect/Engineer _____

Contractor _____

Model _____ Qty _____

Notes _____

Installation profile

