

Siostone Collection

Undermount 50/50 Double Bowl Model SIO-3319DU



SIO-3319DU

FEATURES

- 80% quartz and granite
- 9-1/2" depth
- Intrinsically hygienic non-porous surface
- Antibacterial protection with silver ion Microstop
- Silky to the touch, 3 times harder than natural granite
- Food-safe, UV-stable-will not fade • Color-fast throughout
- Heat resistance to +500°F
- Highest resistance to thermal shock, scratches and chips
- Ariapure® features odor and pollutant disinfection
- Fits 36" sink base
- Supplied with cutout template, fasteners and instructions
- Limited Lifetime Warranty

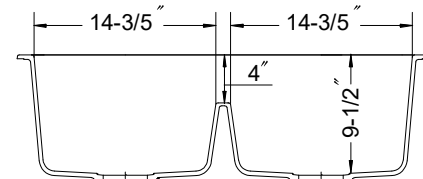
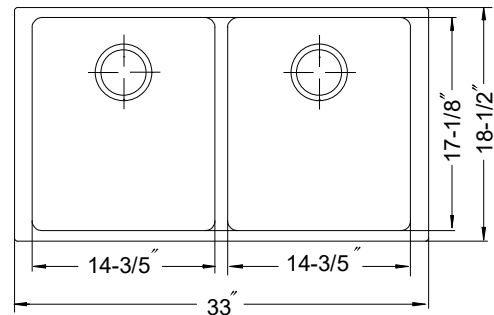

OPTIONAL COLORS



OVERALL DIMENSIONS	EACH BOWL	CUTOUT SIZE	PACKAGING*	WEIGHT*
33" x 18-1/2"	14-3/5" x 17-1/8"	See Template	1/10 pcs.	48/520lbs.

*Standard packaging: Single boxed /Pallet of single boxed.
All dimensions are in inches. Specifications subject to change without notice.

OPTIONAL ACCESSORIES

Bottom Grid: CWG-1315R (Right Bowl)
CWG-1315L (Left Bowl)

Strainer Options: Stainless steel strainers,
Color strainers, Color Disposal flanges

Project/Job name _____

Architect/Engineer _____

Contractor _____

Model _____ Q'ty _____

Notes _____